IFB R5a

Synthesized UHF Beltpack Receiver



Wireless IFB (interruptible fold back) systems are used for talent cueing and crew communications in broadcast and motion picture production. In other cases, the IFB system is used to monitor program audio during a production. The IFB R5a receiver can be configured for a variety of applications, yet it retains the simplicity needed for untrained users to easily operate.

The default frequency of the receiver is set by two rotary switches on the side panel. Up to five additional frequencies can also be programmed into the receiver memory using the scan mode. If more than one frequency is stored in the receiver, the operator can scroll through the stored frequencies by simply pressing the volume control knob.

The design uses +/-20 kHz FM deviation for efficient use of the bandwidth, with compandor noise reduction circuitry for an excellent signal to noise ratio. A super-sonic Pilot Tone signal controls the audio output squelch to aid in accurate scanning and keep the receiver silent when the transmitter is turned off.

Basic operation is simply a matter of rotating the knob to turn power on and adjusting the volume level. Additional frequencies are added by holding the knob in until the LED begins blinking and the receiver begins to scan. The LED stops blinking and scanning pauses when the receiver locates a signal. A long button push at this point stores the additional channel and a short button push continues scanning.

A special button push sequence is required to set the receiver into the programming mode to prevent accidental changes to the receiver memory. Simplified instructions are laser engraved into the housing of the receiver.

TECHNICAL DATA

Feature Highlights

- **Preset (default) frequency can be set without power or transmitter signal**
- **Scan mode stores up to five additional frequencies**
- **Multi-color LED and rotary control for programming and operation**
- **High sensitivity for extended operating range indoors and outdoors**
- **Rugged machined aluminum housing**
- **Spring-loaded belt clip**
- **Attached battery door**
- **8 hours battery life (alkaline)**
- **20 hours battery life (lithium)**

The scanning process is performed at two different sensitivity levels. The first scan is performed at a reduced sensitivity to avoid falsely locking onto IM (intermodulation) signals rather than true carriers. This reduced sensitivity scan is necessary when the unit is programmed in close proximity to the transmitter. If no signals are found in the first scan, a single button push will set the receiver to full sensitivity and begin a second scan. Full sensitivity scanning is necessary to program the receiver at a distance away from the transmitter.

The receiver operates on a single 9 volt alkaline or lithium battery. Alkaline battery life is up to 8 hours. Lithium battery life is well over 20 hours. The LED indicator changes color from green, to yellow, to red as the battery voltage declines to provide plenty of warning before operation ceases.

The output connector will automatically switch to match either a stereo or monaural plug with an internal relay. Full output power is available with either type of connector, without the power losses that result from a resistive circuit design. The antenna input is provided by the shield of the cable and headset or earphone connected to the output jack.



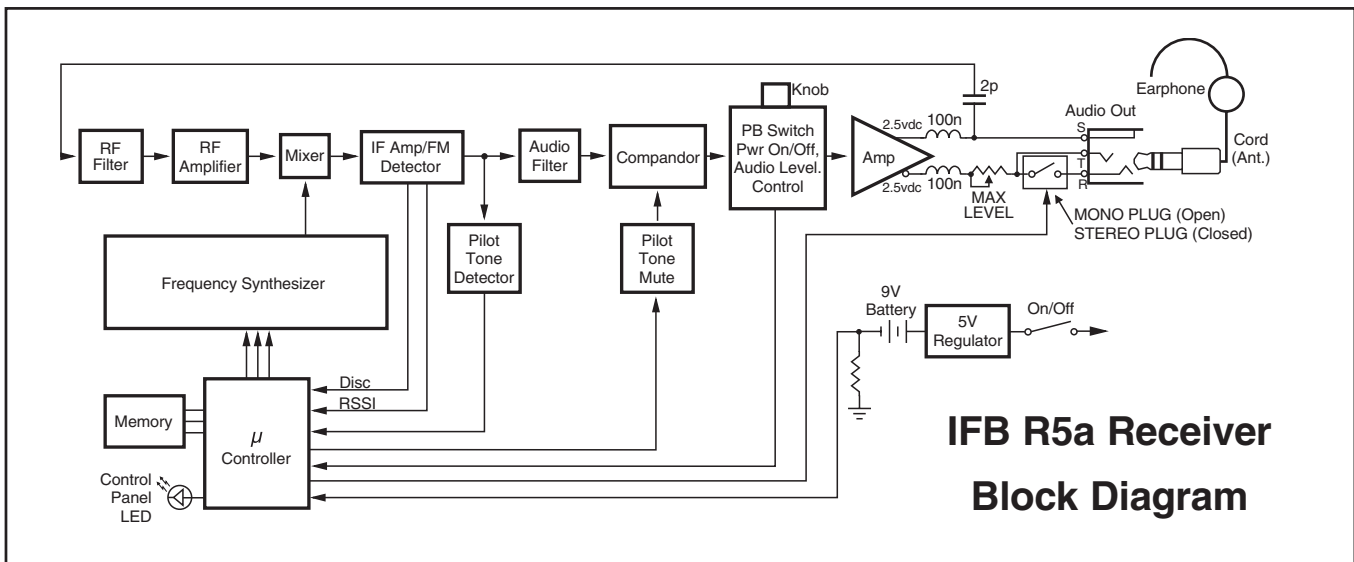

The incoming RF signal is filtered and amplified, then mixed down to the IF frequency with a microprocessor controlled synthesizer. The pilot tone signal is on a different frequency than Lectrosonics wireless microphone systems to prevent interference when the wireless microphone and IFB systems are used in the same location. The audio signal processing includes compandor noise reduction for low noise and excellent intelligibility.

The receiver will drive a wide variety of earbuds, headphones and induction neck loops at substantial levels, with loads from 16 Ohms to 600 Ohms.

The receiver is housed in a rugged machined aluminum package. A spring-loaded belt clip provides a secure mounting on a wide variety of belts, pockets and fabrics. The belt clip is removable to reduce its size and allow mounting into other types of bags and belt worn mounting systems common in field production.

All nomenclature is laser engraved into the housing and the side panel to withstand physical abrasion and heavy use. A condensed instruction set is also laser etched into the side panel of the receiver.

A rotating, aluminum battery door remains attached to the housing when opened so it cannot be lost. The door is spring-loaded to lock into position and maintain pressure on the battery when closed.



Operating frequencies: 537.600 to 862.000 MHz in 25.6 MHz blocks; min. channel spacing 25kHz
Frequency control: Crystal Controlled PLL
Sensitivity: 1 uv (20 dB SINAD)
Signal/Noise ratio: 95 dB A-weighted
Squelch quieting: 50 dB
AM rejection: 50 dB, 10 uV to 100 mV
Modulation acceptance: ±20 kHz
Spurious rejection: Greater than 70 dB
Third order intercept: 0 dBm
Frequency response: 100 Hz to 10 kHz, (±1db)
Pilot tone: 29.997 kHz, 4.5 kHz deviation (fixed crystal controlled)
Audio output: 1V RMS into 50 Ohms minimum
Antenna: Headphone cable

Programmable memory: Switches set default frequency; up to five additional frequencies can be stored in memory
Front panel controls: Single knob controls Audio Output Level, Power on, programming and Scan Frequency Selection
Indicators: Multi-color LED indicator for power on and battery status. Blinks to indicate channel number and during scanning.
Power requirement: 9V alkaline battery lasts about 8 hours; 9V lithium battery lasts about 20 hours
Power consumption: 60 mA
Weight: 7.3 oz (207 gms) with battery
Size: 3.6 x 2.4 x 0.8 inches (housing only) (belt clip and knob extend beyond the housing)

